

Sensors “Mechanical Oscillations” (230 V, 50/60 Hz) 1012850
Sensors “Mechanical Oscillations” (115 V, 50/60 Hz) 1012851

Instruction manual

10/16 TL/ALF

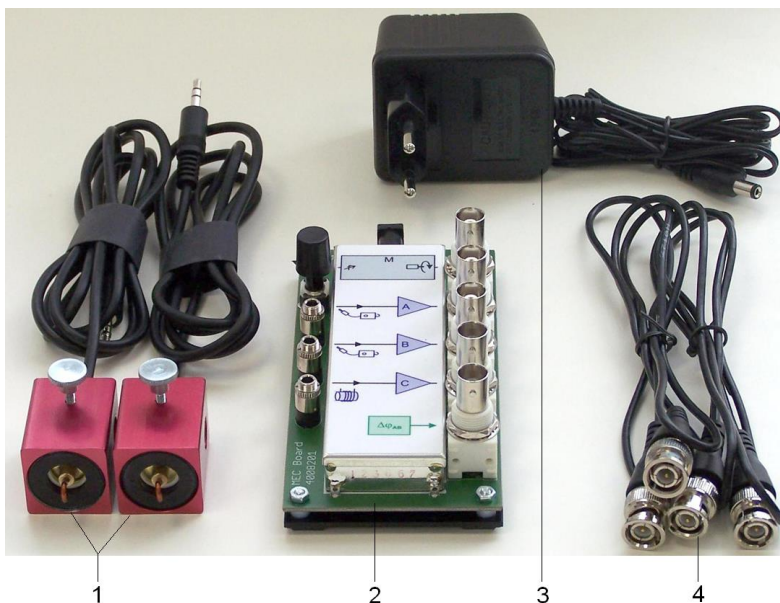

- 1 Dynamic force sensors
- 2 MEC operating electronics
- 3 Plug-in power supply, 230 V (for 1012850),
not shown:
Plug-in power supply, 115 V (for 1012851)
- 4 HF cable

1. Safety instructions

The equipment set Sensors “Mechanical Oscillations” complies with safety regulations for electronic measuring, control and laboratory instruments as specified in DIN EN 61010 part 1. It is designed for operation in dry rooms which are suitable for electrical equipment.

Safe operation of the equipment can be guaranteed as long as it is used in accordance with specifications. Safety is not, however, guaranteed if the equipment is handled incorrectly or without due caution.

2. Description

The equipment set Sensors “Mechanical Oscillations” is intended for recording and analysing mechanical oscillations with the help of an oscil-

loscope. Force sensors which dynamically detect the force along their axis are used for this.

The set with the order number 1012850 is designed for a mains voltage of 230 V ($\pm 10\%$) while 1012851 is made for 115 V ($\pm 10\%$).

2.1 Dynamic force sensor

The dynamic force sensors can be attached to stand rods of 10 mm in diameter or to the SW cross bar from the Stand Equipment “Mechanical Oscillations” set (1012849). They operate by means of the piezo-electric effect.

A force applied to the hook causes the piezo-crystal to charge up, whereby the charge is proportional to the applied force within certain limits. The dynamic characteristic is determined by the finite junction resistance within the piezo-electric material and that of the impedance converter in the associated electronics.

Dynamic force sensor set-up

The sensors are optimally designed to be mounted on stands assembled from the Stand Equipment “Mechanical Oscillations” set (1012849). (See instructions for pendulums listed below.)

In addition, they can be mounted on plates or on any rods of 10-mm diameter by means of their knurled screw.

Caution: Dynamic force sensors must not be subjected to mechanical overloading

- Neither sensor hook may be loaded with more than 5N in the axial direction and 1 N in transverse direction.
- Be especially careful with the maximum loading force when assembling the system or suspending loops or springs from the hook.

2.2 MEC electronics board

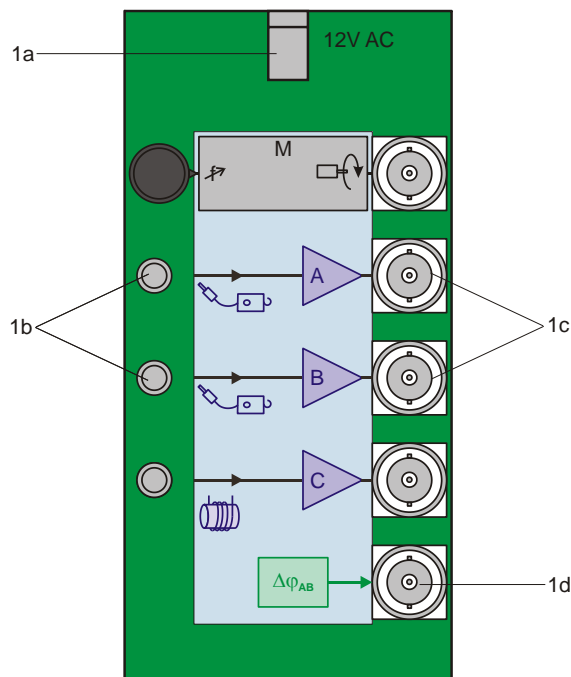

Fig. 1 MEC electronics board

- 1a Connector for plug-in mains supply
- 1b A and B inputs for dynamic force sensors
- 1c A and B outputs for dynamic force sensors
- 1d $\Delta\varphi_{AB}$ output for phase detector

Amplifier channels

Amplifier channels A and B on the MEC electronics board are used in conjunction with the dynamic force sensors. The board converts the signals from both sensors to make them suitable for display in an oscilloscope or other display instrument. The two channels have high internal

resistance. In addition, the phase difference between the two signals can also be evaluated and output. The other inputs on the board are not used for this purpose.

Phase detector

A phase detector compares the waveforms for channels A and B in the time domain to determine the difference in phase between them. Output $\Delta\varphi_{AB}$ supplies the actual phase difference $\Delta\varphi_{AB}$ in the form of a DC voltage between 8 V ($\Delta\varphi = 0^\circ$) and +8 V ($\Delta\varphi = 180^\circ$).

3. Contents

- 2 Dynamic force sensors
- 2 HF cables
- 1 MEC electronics board
- 1 Plug-in power supply, 12 V AC

4. Technical data

Dynamic force sensor

Maximum force	
Axial plane:	5 N
Radial plane:	1 N
Lower frequency limit:	0.2 Hz
Connector:	3.5-mm jack plug
Length of cable	0.8 m
Dimensions:	52 x 37 x 26 mm approx.
Weight:	80 g approx.

Electronic board

Power supplied via plug-in mains transformer	
Input sockets:	3.5-mm jack sockets
Output sockets:	BNC
Amplifier A, B:	Output ± 8 V, $R_i = 100$ M Ω $R_a = 1$ k Ω
Phase detector (XOR):	Output ± 8 V, $R_a = 1$ k Ω
Dimensions:	65 x 100 x 40 mm approx.

Plug-in power supply for 1012850

Primary side:	230 V, 50/60 Hz
Secondary side:	12 V AC; 700 mA

Plug-in power supply for 1012851

Primary side:	115 V, 50/60 Hz
Secondary side:	12 V AC; 500 mA

- Only power the MEC electronics board from the supplied 12 V AC mains transformer.

5. Experiments

The following equipment is recommended for carrying out experiments on mechanical oscillations. Use of a USB oscilloscope means that oscilloscope software can be used to display, evaluate and analyse oscillations on a PC.

Alternatively, any conventional oscilloscope can also be used.

5.1 Wilberforce pendulum

1 Supplementary Kit "Wilberforce Pendulum"	1012844
1 Stand Equipment "Mechanical Oscillations"	1012849
1 Sensors "Mechanical Oscillations" @230V	1012850
or @115V	1012851
1 USB Oscilloscope 2x 50 MHz	1017264
1 PC, operating system Win XP, Vista, Win 7	
or	
1 Analogue oscilloscope 2x 30 MHz	1002727

5.2 Physical pendulum

1 Supplementary Kit "Physical Pendulum"	1012853
1 Stand Equipment "Mechanical Oscillations"	1012849
1 Sensors "Mechanical Oscillations" @230V	1012850
or @115V	1012851
1 USB Oscilloscope 2x 50 MHz	1017264
1 PC, operating system Win XP, Vista, Win 7	
or	
1 Analogue oscilloscope 2x 30 MHz	1002727

5.3 String pendulum

1 Supplementary Kit "String Pendulum"	1012854
1 Stand Equipment "Mechanical Oscillations"	1012849
1 Sensors "Mechanical Oscillations" @230V	1012850
or @115V	1012851
1 USB Oscilloscope 2x 50 MHz	1017264
1 PC, operating system Win XP, Vista, Win 7	
or	
1 Analogue oscilloscope 2x 30 MHz	1002727

6. Disposal

- The packaging should be disposed of at local recycling points.
- Should you need to dispose of the equipment itself, never throw it away in normal domestic waste. If being used in private households it can be disposed of at the local public waste disposal authority.
- Comply with the applicable regulations for the disposal of electrical equipment.

